

RM2000 Pulveriser MK3

Processing large samples up to 1500g.

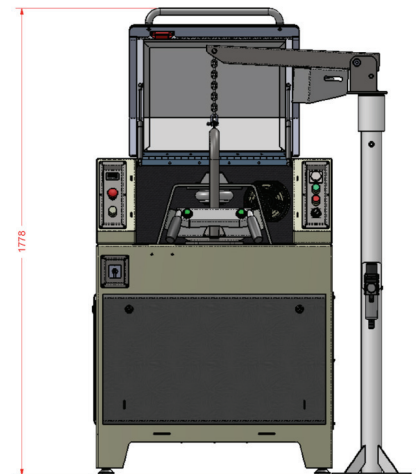
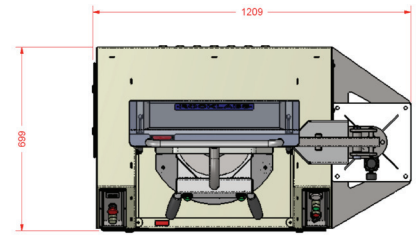

Chrome Head
& Carbon Head

The main features.

- Two handed head clamping operation
- Two airbags for superior Head location
- New head location plate, hard wearing & reversible
- One piece powder coated metal cabinet
- Dust extraction pickup
- New pneumatic control valve & airbag clamp plate
- Range of smaller heads: 350 - 1000gms
- Sound insulated to 80db

The process.

The ROCKLABS RM2000 is designed to process large samples up to 1500g with a final particle size of -75microns.

The RM2000 optional pneumatically operated lifter for assisted head locating during loading and unloading of each sample.

RM2000 Pulveriser MK3

Processing large samples up to 1500g.

Specifications

Motor power	2.2kW, Single phase or three phase
Maximum input lump size	10mm maximum
Product size	Pulverized to - 75µm
Width x Height x Depth	1210 x 1800 x 700mm
Weight	390kg
Sample size	From 200g to 1500g
Dust extraction	Built-in air extraction fan & dust extraction pickup
Options	Pneumatic Lifting device
Warranty	Rocklabs standard equipment is warranted against manufacturing defects for the period of one year, or the first 2000 operating hours, whichever comes first. The warranty period commences on the date of dispatch. During the warranty period, any machine component proven to have a manufacturing defect causing premature failure will be replaced, at no charge for the replacement part. Freight terms are EX WORKS for all warranty replacement parts (all costs relating to shipping, customs charges, duties, taxes and insurance are the customers' responsibility from dispatch at Rocklab's facility). This warranty does not cover failure due to accidents, abuse, misuse, or use of non-Rocklabs parts & heads, negligence or acts of God.

*Head Options

Carbon	1500g
Chrome	1500g

Shipping Dimensions

Width	1115mm
Height	1460mm
Depth	930mm
Weight	420kg

*For more information please contact us on the details below or visit the website for a list of international agents.

ROCKLABS Ltd.
P.O Box 18-142, Glen Innes 1743,
Auckland, New Zealand.

P 64 9 634 7696
F 64 9 634 6896
E sales@rocklabs.com

www.rocklabs.com